

A. Koski, R. Bandelmann and S. Wolff
Deutsches Elektronen-Synchrotron DESY
Postfach, D-22603 Hamburg, Germany

Superconducting Magnet Package for the TESLA Test Facility

Paper presented at the 14th International Conference on Magnet Technology,
Tampere, Finland, June 11–16 1995.

Superconducting Magnet Package for the TESLA Test Facility

A. Koski*, R. Bandelmann and S. Wolff

Deutsches Elektronen-Synchrotron DESY, Postfach, D-22603 Hamburg, Germany

Abstract—The magnetic lattice of the TeV electron superconducting linear accelerator (TESLA) will consist of superconducting quadrupoles for beam focusing and superconducting correction dipoles for beam steering, incorporated in the cryostats containing the superconducting cavities. This report describes the design of these magnets, presenting details of the magnetic as well as the mechanical design. The measured characteristics of the TESLA Test Facility (TTF) quadrupoles and dipoles are compared to the results obtained from numerical computations.

I. INTRODUCTION

The TESLA Test Facility (TTF) located at DESY, Hamburg, will include a 500–800 MeV linac. The main body of the linac consists of four cryomodules each containing eight 1 m long nine-cell superconducting cavities operating at 1.3 GHz with a base accelerating gradient of 15 MV/m. At the end of each 12.2 m long cryomodule, a superconducting magnet package will be installed.

The magnet package, as shown in Fig. 1, consists of

- a superferric quadrupole doublet, powered in series;
- two pairs of superconducting dipole steering coils inside the quadrupole yoke bore;
- an RF beam position monitor (BPM) consisting of a pill-box RF cavity, rigidly connected to the quadrupole yoke;
- a stainless steel beam pipe through the magnet bore, evacuated to UHV, rigidly connected to the BPM, to the quadrupole doublet and, through a bellow, to the nearest cavity. The pipe also absorbs the unwanted higher order modes (HOM) from electromagnetic energy leaking out from the cavities. For this reason a cooling sleeve around it is provided, in which 70 K He gas is circulated;

Manuscript received June 13, 1995.

S. Wolff, phone +49-40-8998-3409, e-mail swolff@desy.de

This work was supported in part by the Research Institute of High Energy Physics in Finland (SEFT).

*On leave from the Tampere University of Technology, Finland.

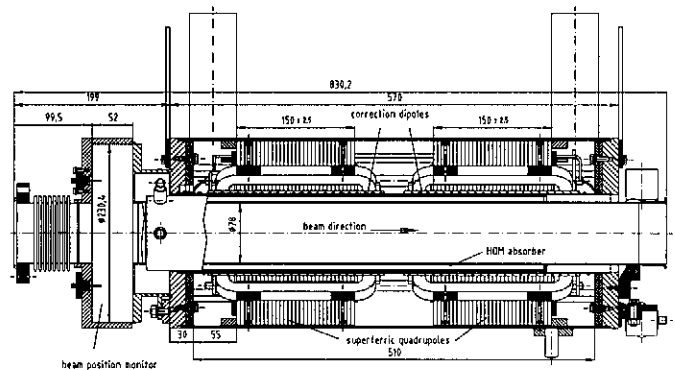

Fig. 1. The superconducting magnet package. Dimensions in mm's.

- eight current leads for the quadrupole doublet and the dipole steering coils, enclosed in a special pipe running from the helium vessel to a flange on the cryostat vacuum vessel. The leads are cooled by cold He gas. At the cold end, the pipe begins at a connection box in which the current leads are connected to the magnet coil ends.

The magnet package will be housed in a stainless steel vessel and cooled by 4 K liquid helium.

The assembly of the first cryomodule is expected to be completed by November 1995. Details of the overall design of the TTF have been described in a full report by TESLA Collaboration [1].

II. GENERAL DESIGN

The limited space in the cryomodule and the demand for a cost efficient design both prefer the superferric quadrupole magnet configuration. The quadrupoles must have a relatively large aperture, with a radius of 56 mm, to provide room for the HOM absorber, the annular space for the insulating vacuum, the inner helium vessel tube and the correction dipoles wound on it. The dipole windings can also only have a single winding layer due to the limited space.

The length of the quadrupoles was determined by the available space. A yoke length of 150 mm was considered to be sufficient. The straight sections of the coils are longer than the pole aperture and long enough to gain experience with the winding technique.

TABLE I
MAGNET PACKAGE DESIGN PARAMETERS

	Quadrupole	Correction dipole
Magnets per module	2	4
Magnet type	superferric	single layer
Magnet length	150 mm	150 mm
Inner diameter	56 mm	52.0 mm
Outer diameter	238 mm	55.5 mm
Distance between centers	250 mm ^a	250 mm

^aThe 100 mm gap is needed for quadrupole coil ends.

The basics of the linac optics were determined by first order beam transport calculations [1]. According to these results, a gradient of 0.0204 T/m for each MeV of beam energy for each 0.15 m long quadrupole will be needed. Since the maximum achievable gradients with superferric quadrupoles are about 20 T/m, the available focal strengths will be sufficient. The dipole coil straight sections have the same length as the quadrupoles. Table I lists the main design parameters of the magnet package.

III. SUPERFERRIC QUADRUPOLE

A. Magnetic Design

The magnetic design of the quadrupole was done first in 2-D with the finite element codes ANSYS by Swanson Analysis Systems Inc. [2] and Opera-2d by Vector Fields [3]. Both codes use the vector potential formulation in 2-D static analysis and the results obtained agreed very nicely. Quadratic finite elements are well suited to the solution of a quadrupole magnet, in which the field varies linearly in the magnet aperture.

To keep the pole design as simple as possible, the geometry of the poles was determined by the procedure depicted in Fig. 2. The pole face contour is constructed from one arc, being a section of a circle of radius R , and two straight sections on either side, tangential to the arc. Setting the radius R to some value, in this design $R = 56.5$ mm, and changing the angle α , the unwanted multipoles can be minimized. To achieve the best accuracy, the contribution of the higher order harmonics was computed first at a larger radius, normally $r = 30$ mm, and then scaled down to the reference radius $r_0 = 10$ mm.

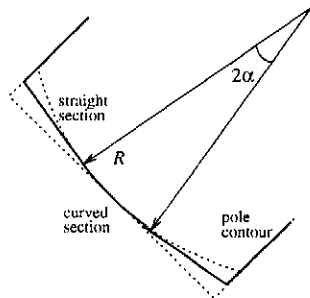

Fig. 2. The construction of the pole face geometry.

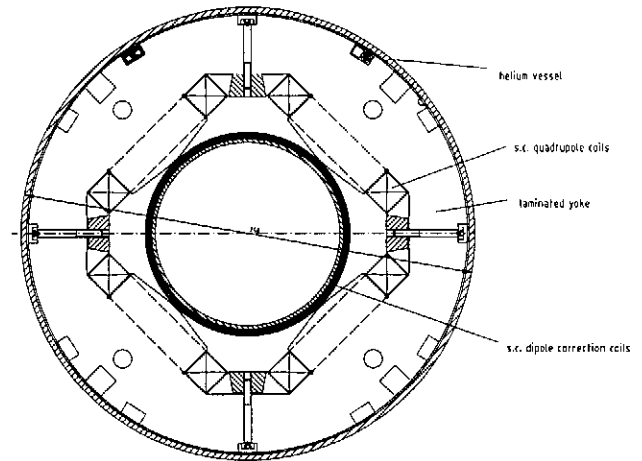

Fig. 3. The cross-section of the s.c. magnet package.

The design was optimized for a quadrupole current of 30 A, which was thought to correspond approximately to the gradient and integrated gradient of 11–12 T/m and 2.0 T, respectively. In addition, these are roughly the projected average field values needed in the TTF.

As a result of the 2-D computations, with $\alpha = 7.4^\circ$ the most harmful higher harmonic, the dodecapole, is effectively zero at a current of 30.6 A. At this current and at the reference radius $r_0 = 10$ mm, the ratio of the next allowed harmonic, the 20-pole, to the quadrupole field is $-7.9 \cdot 10^{-8}$ and higher order terms are negligible. The saturation of the iron changes the dodecapole ratio from $5.3 \cdot 10^{-6}$ at 10 A to $-4.46 \cdot 10^{-5}$ at 60 A, while the higher multipoles change much less.

The 2-D computations also showed, that neither the designed hole for bolting the yoke laminations together nor the notches for cabling on the outer surface of the yoke change the field quality noticeably.

The 3-D computations were done with the Opera-3d [3] and ANSYS with a single 45° half-pole model. A big part of the computational effort in 3-D analysis went into finding a cross-sectional finite element mesh that resulted in good results without being too dense. The mesh geometry was examined by using a pseudo 2-D geometry, with only one layer of finite elements in the axial direction and defining $B_{\perp} = 0$ on the faces. By refining this 3-D mesh until the results were very close to those obtained from the 2-D model, the final cross-sectional mesh was obtained.

For the full 3-D computations, the pseudo 2-D model was expanded in the third dimension. The element lengths were then shortened until there were no noticeable changes in the results. In the end region much shorter elements had to be used than elsewhere.

The final cross-section of the superferric quadrupole with the correction coils is shown in Fig. 3.

The coils around the iron poles are of the racetrack type wound from a rectangular superconductor with a cross-section of 0.475 mm^2 including the varnish insulation. This conductor has a short sample critical current

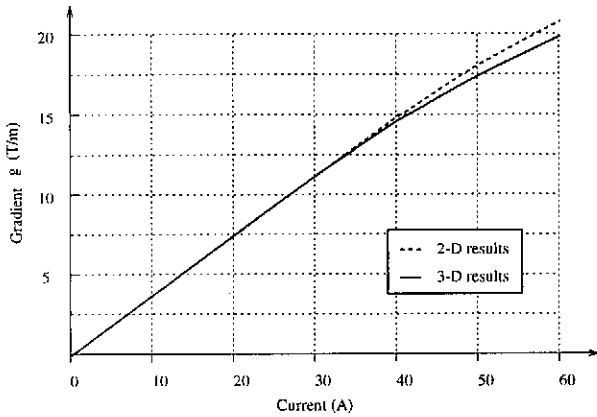

Fig. 4. Field gradient vs. quadrupole current at the magnet center obtained from 2-D and 3-D computations.

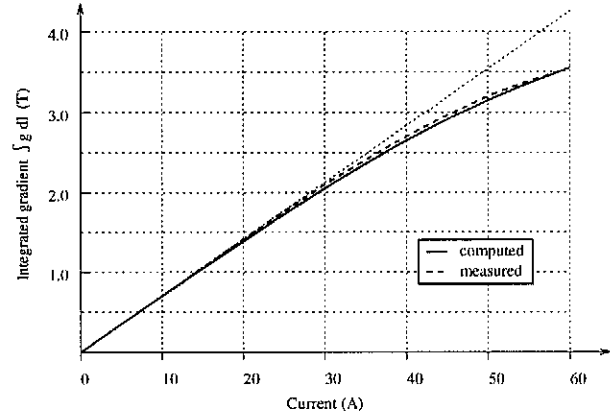

Fig. 5. Integrated field gradient vs. quadrupole current. Both computed and measured curve are shown.

I_{SS} of 112 A at 4.6 T and at a temperature of 4.6 K.

Fig. 4 shows the computed field gradient in the magnet center obtained from the 2-D and the 3-D models and Fig. 5 the computed and measured gradients integrated over the length of the magnet, as functions of the quadrupole current. The 3-D end effect is clearly visible in the gradient in Fig. 4, reducing the gradient at higher excitation levels below the value obtained from the 2-D computations. The dotted linear curve in Fig. 5 is extrapolated from the low excitation results and shows that at 60 A the reduction in the integrated gradient due to the iron saturation is about 15 %.

Fig. 6 displays the field gradient along the quadrupole axis for the magnet half length. The field amplitude already begins to decrease far from the end of the yoke.

The integrated relative multipole coefficients b_6 and b_{10} as functions of current at the reference radius of $r_0 = 10$ mm are shown in Fig. 7. The quadrupole harmonics were measured at room temperature with quadrupole current I_q of 0.5 A. The results agree quite well with the computed ones, see Table III.

Some of the results related to the magnetic design of the TTF quadrupoles were already published in another report [4].

TABLE II
MAIN PARAMETERS OF SUPERFERRIC QUADRUPOLE

Coils per magnet	4
Number of turns per coil	464
Wire size	0.95 mm × 0.5 mm
Maximum current	60.0 A
Gradient at 38.1 A	14.0 T/m
at 48.3 A	17.0 T/m
at 60 A	19.88 T/m
Integrated gradient at 60 A	3.54 T
Effective length at 10 A	185 mm
at 60 A	178 mm
Peak field in winding at 60 A	2.11 T
Self inductance at 60 A	608 mH

B. Fabrication

The quadrupole coils are wet (epoxy resin) wound on a mandrel from a varnish insulated wire and cured in an oven. The quadrupole yoke is made of 5 mm thick punched laminations assembled on a tool and locked through keys which give the required position accuracy (0.02 mm). The keys are connected through pins and bolts to the outer helium vessel tube and to the end plates of the vessel housing the magnet package.

To detect possible quenches or short circuits a voltage tap wire between the quadrupoles is installed. During a cold test in a vertical bath cryostat no quench was detected up to a quadrupole current of 100 A.

IV. DIPOLE CORRECTION COIL

The dipole correction coils, one pair providing the horizontal and the other the vertical steering, must fit in the space between the quadrupole yoke and the inner tube of the helium vessel. The magnetic field of the correction coil was analyzed and the effect of the iron yoke of the quadrupole at different quadrupole currents was taken into account.

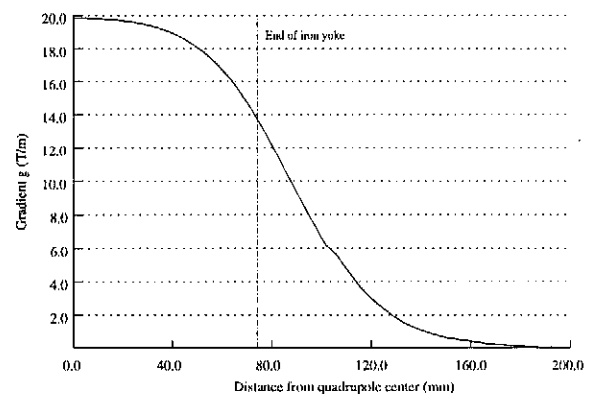

Fig. 6. Gradient along the magnet axis.

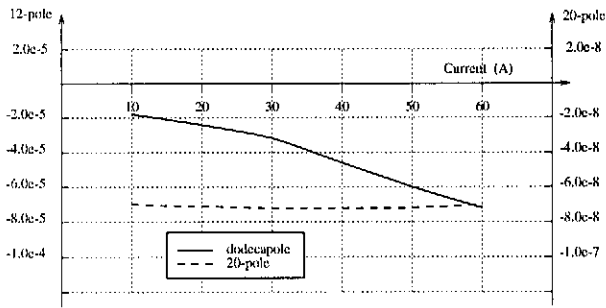

Fig. 7. Integrated relative dodecapole and 20-pole of the quadrupole magnet, at $r_0 = 10$ mm.

TABLE III
COMPUTED AND MEASURED HARMONICS

$r_0 = 10$ mm		Computed	Measured
Quadrupole: $I_q = 0.5$ A	Dodecapole	$1.9 \cdot 10^{-5}$	$2.0 \cdot 10^{-5}$
	20-pole	$7.0 \cdot 10^{-8}$	$5.9 \cdot 10^{-8}$
Dipole: $I_d = 1.0$ A	Sextupole	$-1.7 \cdot 10^{-3}$	$-1.6 \cdot 10^{-3}$
	Decapole	$-7.3 \cdot 10^{-4}$	$-7.9 \cdot 10^{-4}$

To provide a sufficient beam steering capability, roughly 30 turns of superconducting wire with a peak current of 100 A was considered to be enough. The coil sustains thus a sector of about 35° . By changing the azimuthal position of the straight sections, the multipoles can be minimized. However, due to the single layer configuration, the final design has to be a compromise between minimizing the sextupole or the decapole component.

The main parameters of the final design of the correction dipole are given in Table IV. The two values of peak field and peak field integral are given for the two extreme cases of quadrupole current, i.e. for I_q of 0 A and 60 A, respectively, at full dipole current, $I_d = 100$ A. The cross-section of the two dipole coils on the inner helium vessel tube is shown in Fig. 8.

As an air coil, the dipole coil produces a field of 0.0421 T at 100 A. Thus the increase in the peak dipole field due to the quadrupole yoke at full quadrupole current of 60 A is about 40 % and at zero quadrupole current roughly 75 %. The computed and measured harmonics at dipole current I_d of 1.0 A at room temperature are shown in Table III.

An integrated field of 0.01 Tm is already capable of bending a 800 MeV electron beam by 3.75 mrad. Less than half of this value is required to maintain a beam offset of 10 mm throughout the linac to measure the higher order mode excitations.

The second coil of the correction dipole can be used to investigate or eliminate the influence of motion or vibration of the quadrupoles on the beam. An AC current of 1 A in the steering coil is capable of shifting the position of the magnetic center of the quadrupole by $\pm 50 \mu\text{m}$ and compensating for quadrupole motion of the same amount. The output from the accelerometers attached to the cold mass of the quadrupoles may be used to control the power

TABLE IV
MAIN PARAMETERS OF DIPOLE CORRECTION COIL

Number of coils per magnet	2
Number of turns per coil	33
Average radius, inner coil	52.5 mm
outer coil	54.2 mm
Superconducting wire diameter	0.7 mm
Maximum current	100 A
Peak dipole field at $I_d = 100$ A	0.0738–0.0591 T
Integrated field at $I_d = 100$ A	0.0168–0.0132 Tm
Maximum field at conductor, outer coil ^a	1.251 T
Coil self inductance at $I_d = 100$ A	1.1 mH

^a At quadrupole current of 60 A.

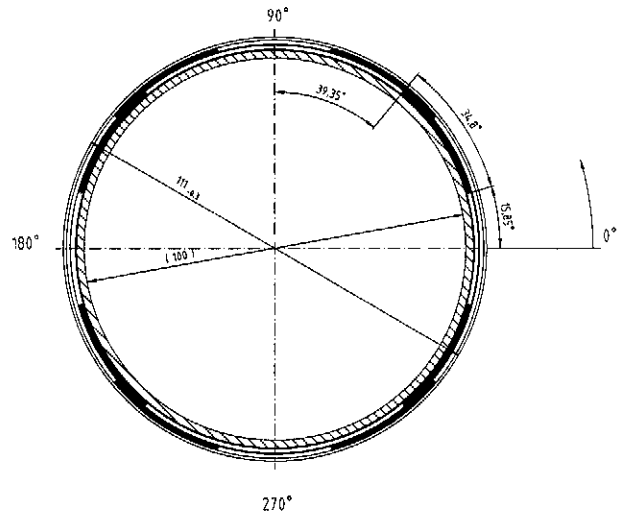

Fig. 8. The cross-section of the dipole correction coils.

supplies of the correction dipoles to correct the vibration.

The main magnetic field strength inside the aperture is a result of energizing the quadrupole. The forces on the correction coils are therefore directed tangentially or radially inwards and outwards and change sign when the polarity of the magnet is reversed. A peak tangential force of 522 N/mm^2 and radial force of 282 N/mm^2 act on the straight section of the dipole. Mechanical support is thus needed to provide sufficient compression to resist the shear stresses.

The dipole coils are wet (epoxy resin) wound from a superconducting wire having a diameter of 0.7 mm and short sample critical current of over 250 A at 5.5 T and at a temperature of 4.6 K. An epoxy impregnated cured unidirectional glass fiber bandage tightens and secures the coils on the tube.

REFERENCES

- [1] D. Edwards, ed., *TESLA Test Facility Linac Design Report*, no. Version 1.0, (Hamburg, Germany), DESY, March 1995.
- [2] Swanson Analysis Systems, Inc., Houston, PA, U.S.A.
- [3] Vector Fields Ltd., 24 Bankside, Kidlington, Oxford, U.K.
- [4] A. Koski, E. Pietarinen, S. Wolff, and L. Kettunen, "Magnetic design of the superconducting quadrupoles for TESLA," Tech. Rep. HU-SEFT R 1993-17, SEFT, University of Helsinki, 1993.